

EN

OPERATING MANUAL
360° TURBO FAN



Table of contents

Notes regarding the operating manual..... 2

Safety 2

Information about the device..... 4

Transport and storage..... 5

Assembly and start-up..... 6

Operation 6

Errors and faults..... 10

Maintenance 10

Technical annex..... 10

Disposal 11

Notes regarding the operating manual

Symbols



Warning of electrical voltage

This symbol indicates dangers to the life and health of persons due to electrical voltage.



Warning

This signal word indicates a hazard with an average risk level which, if not avoided, can result in serious injury or death.



Caution

This signal word indicates a hazard with a low risk level which, if not avoided, can result in minor or moderate injury.

Note

This signal word indicates important information (e.g. material damage), but does not indicate hazards.



Info

Information marked with this symbol helps you to carry out your tasks quickly and safely.



Follow the manual

Information marked with this symbol indicates that the operating manual must be observed.

You can download the current version of the operating manual and the EU declaration of conformity via the following link:

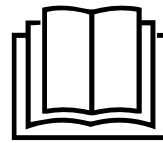

TVE 100



<https://hub.trotec.com/?id=45844>

Safety

Read this manual carefully before starting or using the device. Always store the manual in the immediate vicinity of the device or its site of use.



Warning

Read all safety warnings and all instructions.

Failure to follow the warnings and instructions may result in electric shock, fire and/or serious injury.

Save all warnings and instructions for future reference.

This appliance can be used by children aged from 8 years and above and persons with reduced physical, sensory or mental capabilities or lack of experience and knowledge if they have been given supervision or instruction concerning use of the appliance in a safe way and understand the hazards involved.

Children shall not play with the appliance. Cleaning and user maintenance shall not be made by children without supervision.

- Do not use the device in potentially explosive rooms or areas and do not install it there.
- Do not use the device in aggressive atmosphere.
- Only put up the device in an upright, stable position on firm ground.
- Let the device dry out after a wet clean. Do not operate it when wet.
- Do not use the device with wet or damp hands.
- Do not expose the device to directly squirting water.
- Never insert any objects or limbs into the device.
- Do not cover the device during operation.
- Do not sit on the device.
- This appliance is not a toy. Keep away from children and animals. Do not leave the device unattended during operation.
- Check accessories and connection parts for possible damage prior to every use of the device. Do not use any defective devices or device parts.

- Ensure that all electric cables outside of the device are protected from damage (e.g. caused by animals). Never use the device if electric cables or the power connection are damaged!
- The mains connection must correspond to the specifications in the Technical annex.
- Insert the mains plug into a properly fused mains socket.
- Observe the technical data when selecting extensions to the power cable. Completely unroll the extension cable. Avoid electrical overload.
- Before carrying out maintenance, care or repair work on the device, remove the mains plug from the mains socket. Hold onto the mains plug while doing so.
- Switch the device off and disconnect the power cable from the mains socket when the device is not in use.
- Do not under any circumstances use the device if you detect damages on the mains plug or power cable. If the power cable is damaged, it must be replaced by the manufacturer, its service agent or similarly qualified persons in order to avoid a hazard. Defective power cables pose a serious health risk!
- When positioning the device, observe the minimum distances from walls and other objects as well as the storage and operating conditions specified in the Technical annex.
- Make sure that the air inlet and outlet are not obstructed.
- Make sure that there are no loose items or dirt located in the immediate surroundings of air inlet and air outlet.
- When unmounted, the device should be neither operated nor connected to the mains.
- Improper installation can lead to a fire, electric shock or severe personal injury.
- The device is provided with an overheating protection which is activated by overheating of the device (when exceeding the operating temperature). In such an event the device switches off automatically.
- Do not ingest coin/button cell batteries! If a coin/button cell battery is swallowed, it can cause severe internal burns within 2 hours! These burns can lead to death!
- If you think batteries might have been swallowed or otherwise entered the body, seek medical attention immediately!
- Keep new and used batteries and an open battery compartment away from children.
- If the battery compartment does not close securely, stop using the product via the remote control.
- Batteries contain materials hazardous to the environment. Dispose of the batteries according to the national regulations.
- Do not insert rechargeable batteries into the remote control.

Intended use

Only use the device TVE 100 as table fan for the ventilation of interior spaces whilst adhering to the technical data.

Foreseeable misuse

- Do not place the device on wet or flooded ground.
- Do not place any objects, e.g. clothing, on the device.
- Do not use the device out of doors.
- Any operation other than as described in this manual is prohibited. Non-observance renders all claims for liability and guarantee null and void.
- Any unauthorised modifications, alterations or structural changes to the device are forbidden.

Personnel qualifications

People who use this device must:

- be aware of the dangers that occur when working with electric devices in damp areas.
- have read and understood the operating manual, especially the Safety chapter.

Residual risks



Warning of electrical voltage

Work on the electrical components must only be carried out by an authorised specialist company!



Warning of electrical voltage

Before any work on the device, remove the mains plug from the mains socket!
Do not touch the mains plug with wet or damp hands. Hold onto the mains plug while pulling the power cable out of the mains socket.



Warning

Dangers can occur at the device when it is used by untrained people in an unprofessional or improper way! Observe the personnel qualifications!



Warning

The device is not a toy and does not belong in the hands of children.



Warning

Risk of suffocation!
Do not leave the packaging lying around. Children may use it as a dangerous toy.

Note

Do not use abrasive cleaners or solvents to clean the device.

Behaviour in the event of an emergency

1. Switch the device off.
2. In an emergency, disconnect the device from the mains feed-in: Hold onto the mains plug while pulling the power cable out of the mains socket.
3. Do not reconnect a defective device to the mains.

Information about the device

Device description

The device is suitable for indoor air circulation.

The device comes with the following features:

- 32 speed levels
- adjustable timer function up to 12 hours
- on-demand 90° swing function
- on-demand oscillation function in increments of 30°, 90°, 180° and 360°
- with integrated scented oil tank and diffuser
- dimmable control panel with display timeout
- with remote control
- with transport handle

Device depiction

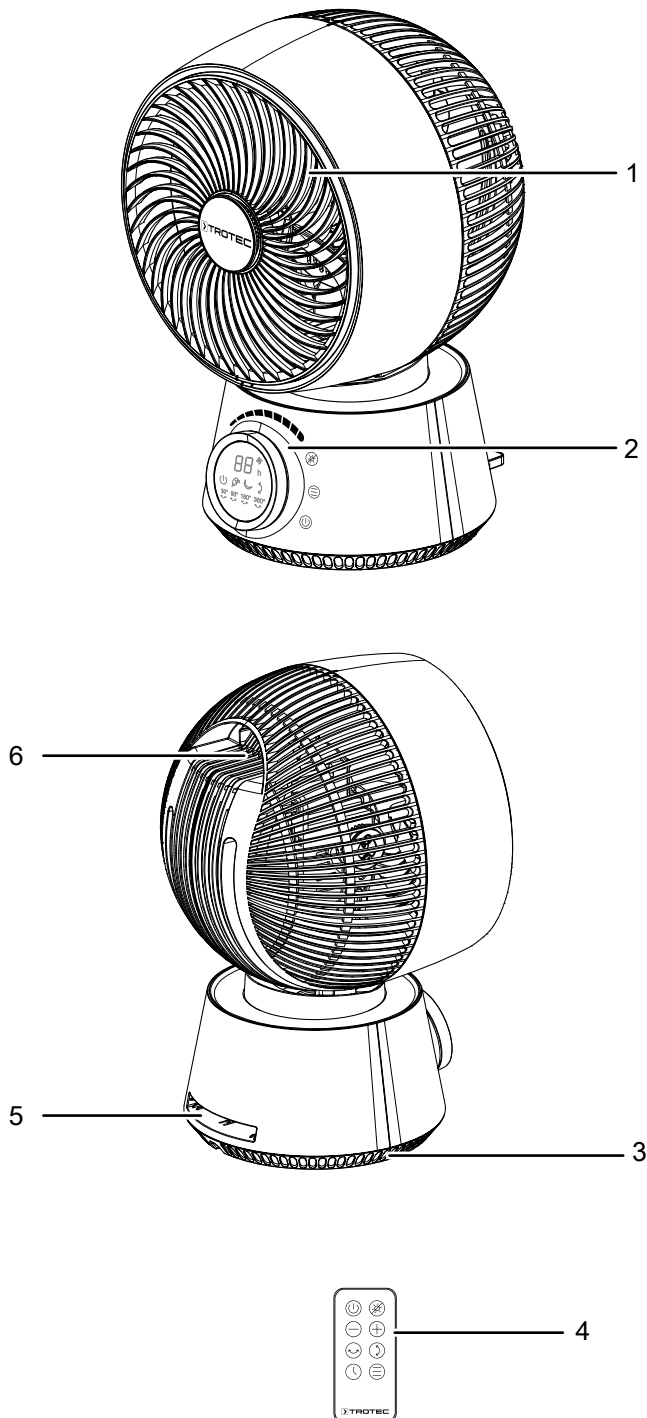

Transport and storage

Note

If you store or transport the device improperly, the device may be damaged.

Note the information regarding transport and storage of the device.

Transport

To make the device easier to transport, it is fitted with a carry handle.

Before transporting the device, observe the following:

- Switch the device off.
- Hold onto the mains plug while pulling the power cable out of the mains socket.
- Do not use the power cable to drag the device.

After transporting the device, proceed as follows:

- Set up the device in an upright position after transport.

Storage

Before storing the device, proceed as follows:

- Switch off the device.
- Hold onto the mains plug while pulling the power cable out of the mains socket.

When the device is not being used, observe the following storage conditions:

- Store the device in a dry location and protected from frost and heat.
- If required, use a cover to protect the device from invasive dust.
- Place no further devices or objects on top of the device to prevent it from being damaged.
- Remove the batteries from the remote control.

| No. | Designation |
|-----|------------------------------------|
| 1 | Fan body |
| 2 | Control panel |
| 3 | Foot |
| 4 | Remote control |
| 5 | Compartment for the remote control |
| 6 | Transport handle |

Assembly and start-up

Scope of delivery

- 1 x Device TVE 100
- 1 x Remote control (without batteries)
- 1 x Manual

Unpacking the device

1. Open the cardboard box and take the device out.
2. Completely remove the packaging.
3. Fully unwind the power cable. Make sure that the power cable is not damaged and that you do not damage it during unwinding.

Start-up

When positioning the device, observe the minimum distance from walls or other objects as described in the chapter Technical annex.

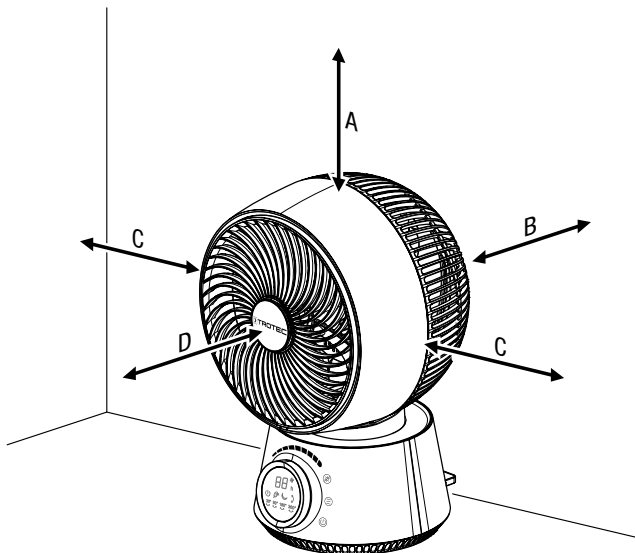

- Before restarting the device, check the condition of the power cable. If there are doubts as to the sound condition, contact the customer service.
- Only put up the device in an upright, stable position on firm ground.
- Do not create tripping hazards when laying the power cable or other electric cables, especially when positioning the device in the middle of the room. Use cable bridges.
- Make sure that extension cables are completely unrolled.
- Make sure that no curtains or other objects interfere with the air flow.

Prior to initial start-up, insert batteries in the remote control.

Inserting batteries into the remote control

Remove the battery compartment (7) underneath the remote control and insert a type CR 2032 battery.

Note

Do not use rechargeable batteries!
Observe the Technical data for start-up.

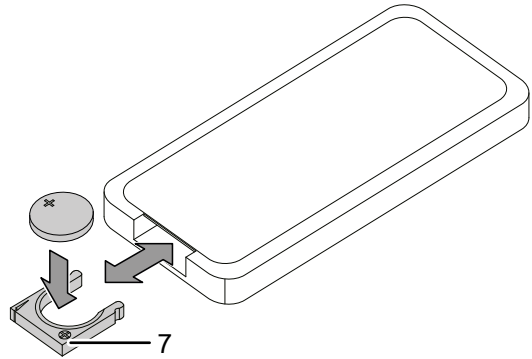

Connecting the power cable

- Insert the mains plug into a properly fused mains socket.

Operation

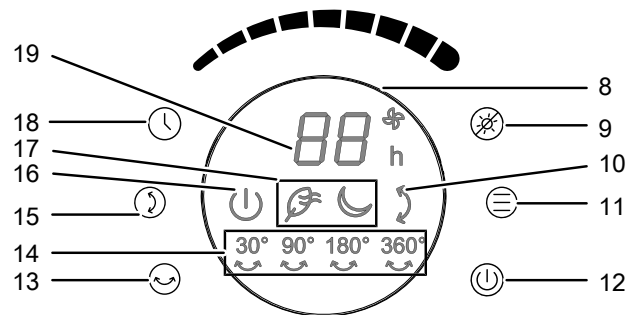

Operating elements

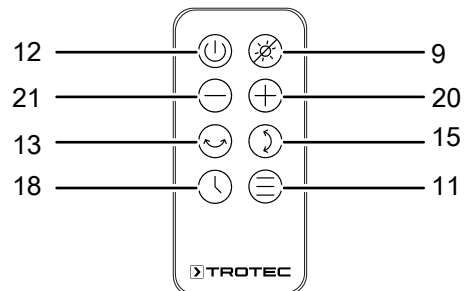

Remote control

All settings of the device can also be made using the remote control included in the scope of delivery.



| No. | Designation | Meaning |
|-----|----------------------------|---|
| 8 | Rotary switch | Setting the fan stage setting the number of hours of the timer |
| 9 | <i>Illumination</i> button | Switching illumination on or off |
| 10 | <i>Swing</i> LED | Is illuminated when the vertical swing function is activated |
| 11 | <i>Mode</i> button | Selecting the operating mode: <i>Normal operation</i> <i>Natural wind</i> <i>Night mode</i> |
| 12 | <i>On/off</i> button | Switching the device on or off |
| 13 | <i>Oscillation</i> button | Switching horizontal oscillation on or off |
| 14 | <i>Oscillation</i> LEDs | The corresponding LED is illuminated when oscillation has been selected for the angles 30°, 90°, 180° or 360°. |
| 15 | <i>Swing</i> button | Switching the vertical swing function on or off |
| 16 | <i>On/off</i> LED | Illuminated when the device is switched on |
| 17 | <i>Mode</i> LEDs | Indicate the selected operating mode:  = <i>natural wind</i>  = <i>night mode</i> |
| 18 | <i>Timer</i> button | Timer function: automatic switch-on and switch-off |
| 19 | Display | Indication of the fan stage and the  LED Indication of the number of hours of the activated timer (1 h to 12 h) and the LED h |
| 20 | <i>Up</i> button | Increasing the fan speed Increasing the number of hours of the activated timer |
| 21 | <i>Down</i> button | Decreasing the fan speed Decreasing the number of hours of the activated timer |

Switching the device on

Once you have completely installed the device as described in the chapter Assembly and start-up, you can switch it on.

- Press the *On/off* button (12).
 - ⇒ The *On/off* LED (16) is illuminated.
 - ⇒ An acoustic signal is emitted and the device starts up in *Normal operation* mode.



Info

When the device is switched on, the display is automatically dimmed after 1 minute.

Setting the operating mode

The device has the following operating modes:

- *Normal operation*
- *Natural wind*
- *Night mode*



Normal operation

Note

When *normal operation* is activated, there is no specific LED to indicate the operating mode.

In *normal operation* mode the fan keeps running at the desired fan stage. The fan stage can be set from 1 to 32 in this operating mode and is indicated on the display (19).



Please proceed as follows to set the fan stage in *normal operation* mode:

- Press the *Mode* button (11) until neither the  LED nor the  LED (17) is illuminated.
 - ⇒ The device runs in *normal operation* mode.
 - ⇒ The  LED is illuminated on the display (19).
- Turn the rotary switch (8) clockwise to increase the fan stage.
Turn the rotary switch (8) counter-clockwise to reduce the fan stage.
 - ⇒ The selected fan stage is shown on the display (19).
 - ⇒ The device keeps running at the set fan stage.

Natural wind

In *natural wind* mode, the fan speed changes continuously to generate a pleasant, natural air stream. You can switch between fan stage 10, 20 and 32 in this mode.

Proceed as follows to switch on the *natural wind* mode:



1. Press the *Mode* button (11) until the  LED (17) is illuminated.
⇒ The device runs in *natural wind* mode.
⇒ The  LED is illuminated on the display (19).
2. Turn the rotary switch (8) clockwise to increase the fan stage.
Turn the rotary switch (8) counter-clockwise to reduce the fan stage.
⇒ The selected fan stage is shown on the display (19).

Night mode

In *night mode*, the device gradually changes the fan stage automatically depending on the selected fan stage. You can switch between fan stage 10, 20 and 32 in this mode.

- At fan stage 10, the device runs permanently at this stage.
- At fan stage 20, the device switches to fan stage 10 after an operating time of 30 minutes and keeps running at this speed.
- At fan stage 32, the device switches to fan stage 20 after an operating time of 30 minutes. After another 30 minutes, the device switches to fan stage 10 and runs permanently at this stage.

Proceed as follows to switch on night mode:

1. Press the *Mode* button (11) until the  LED (17) is illuminated.
⇒ The device runs in *night mode*.
⇒ The  LED is illuminated on the display (19).
2. Turn the rotary switch (8) clockwise to increase the fan stage.
Turn the rotary switch (8) counter-clockwise to reduce the fan stage.
⇒ The selected fan stage is shown on the display (19).

Setting the timer

The timer allows you to program an automatic switch-on/off time in increments of 1 hour up to 12 hours.

Automatic switch-on

- ✓ The device is now in standby mode.
1. Press the *Timer* button (18) to activate the timer.
⇒ The segment display (19) flashes and the LED **h** is illuminated.
 2. Turn the rotary switch (8) clockwise to increase the number of hours of the timer.
Turn the rotary switch (8) counter-clockwise to reduce the number of hours of the timer.
⇒ The selected number of hours until automatic switch-on is indicated in the display (19).

Notes regarding automatic switch-on:

- Manually switching the device on disables the automatic switch-on function.
- If you select 0 hours, the timer will be off.

Automatic switch-off

- ✓ The device is switched on.
- 1. Press the *Timer* button (18) to activate the timer.
 - ⇒ The segment display (19) flashes and the LED **h** is illuminated.
- 2. Turn the rotary switch (8) clockwise to increase the number of hours of the timer.
Turn the rotary switch (8) counter-clockwise to reduce the number of hours of the timer.
 - ⇒ If you set the fan stage at the same time you select automatic switch-off, the fan stage and switch-off time are shown alternately on the display.

Notes regarding automatic switch-off:

- Manually switching the device off disables the automatic switch-off function.
- If you select 0 hours, the timer will be off.

Memory function

When switched on from standby, the device switches back to the preset operating mode, except sleep mode.

Any activated timer will not be saved in the device.

Switching the display on or off

Please proceed as follows to switch the display (19) on or off:

1. Press the *Illumination* button (9) to switch the display off.
 - ⇒ The display switches off.
2. Press any button to switch on the device.
 - ⇒ The display switches on.

Using the horizontal oscillation function

The horizontal oscillation function ensures continuous air circulation by moving the upper fan body (1) to the left and to the right at an angle of 30°, 90°, 180° or 360°.

- ✓ The device is switched on and operating.
- 1. Press the *Oscillation* button (13) several times to activate oscillation for the angle 30°, 90°, 180° or 360°.
 - ⇒ The corresponding *Oscillation* LED (14) will be illuminated.
 - ⇒ The fan body (1) moves continuously to the left and right.

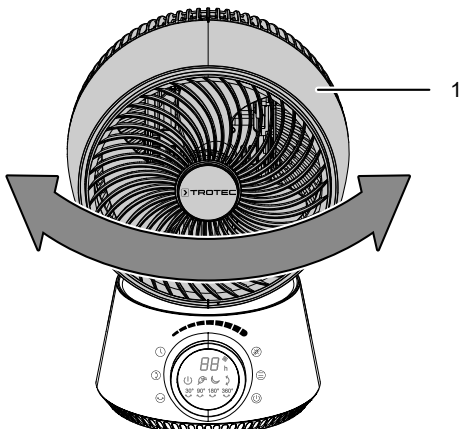

2. If you press the *Oscillation* button (13) again, the oscillation function will be switched off.
 - ⇒ The *Oscillation* LED (14) goes out.
 - ⇒ The device remains in the current position.

Activating the vertical swing function

The vertical swing function ensures continuous air circulation by moving the upper fan body (1) upwards at an angle of 90° and then to the initial position.

- ✓ The device is switched on and operating.
- 1. Press the *Swing* button (15) to activate the vertical swing function.
 - ⇒ The *Swing* LED (10) is illuminated.
 - ⇒ The upper fan body (1) moves continuously upwards and downwards.

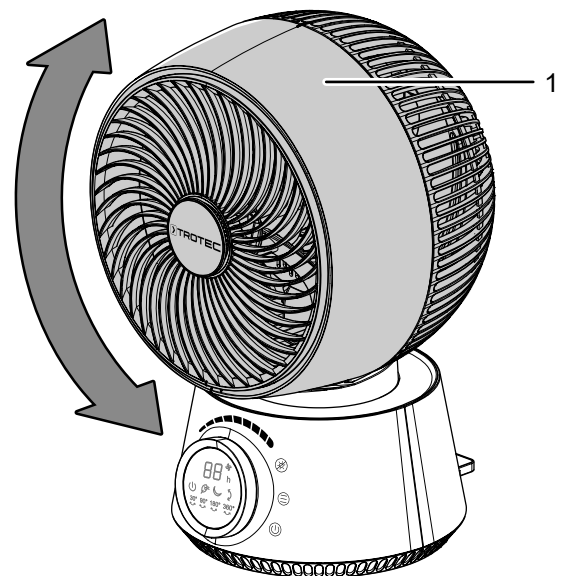

2. If you press the *Swing* button (15) again, the swing function will be switched off.
 - ⇒ The *Swing* LED (10) goes out.
 - ⇒ The device remains in the current position.



Info

You can activate the swing function and the oscillation function at the same time.



Info

All functions can also be made using the remote control included in the scope of delivery.

Shutdown



Warning of electrical voltage

Do not touch the mains plug with wet or damp hands.

- Switch off the device.
- The fan body (1) rotates back to the initial position if you had previously switched on the swing function or oscillation function.
- Hold onto the mains plug while pulling the power cable out of the mains socket.
- Clean the device according to the Maintenance chapter.
- Store the device according to the Transport and storage chapter.

Errors and faults

The device has been checked for proper functioning several times during production. If malfunctions occur nonetheless, check the device according to the following list.

The device does not start:

- Check the power connection.
- Check the power cable and mains plug for damage.
- Check the on-site fusing.
- Wait for 10 minutes before restarting the device. If the device is not starting, have the electricians checked by a specialist company or by Trotec.

The fan does not start:

- Check whether the unit is switched on.
- Check the power supply and whether the plug or cable is defective.

The device is loud or vibrates:

- Check whether the device is set up in a stable and upright position.
- Check whether the device is mounted correctly.

Note

Wait for at least 3 minutes after maintenance and repair work. Only then switch the device back on.

The device still does not operate correctly after these checks:

Please contact the customer service. If necessary, bring the device to an authorised specialist electrical company or to Trotec for repair.

Maintenance

Activities required before starting maintenance



Warning of electrical voltage

Do not touch the mains plug with wet or damp hands.

- Switch the device off.
- Hold onto the mains plug while pulling the power cable out of the mains socket.

Cleaning the housing

Clean the housing with a soft, damp and lint-free cloth. Make sure that no moisture enters the housing. Protect electrical components from moisture. Do not use any aggressive cleaning agents such as cleaning sprays, solvents, alcohol-based or abrasive cleaners to dampen the cloth.

Technical annex

Technical data

| Parameter | Value |
|---|---|
| Model | TVE 100 |
| Fan stages | 32 |
| Air velocity | 6.5 m/s |
| Input voltage | 220 – 240 V / 50 Hz |
| Power input | 26 W |
| Power cable length | 1.75 m |
| Sound pressure level (at 1 m distance, stage 6) | 56 dB(A) |
| Weight | 2.5 kg |
| Dimensions (incl. foot) (length x width x height) | 255 x 237 x 374 (mm) |
| Minimum distance to walls and other objects | top (A): 20 cm rear (B): 20 cm sides (C): 20 cm front (D): 20 cm |
| Battery for the remote control | 1 x CR 2032 |

Disposal



The icon with the crossed-out waste bin on waste electrical or electronic equipment stipulates that this equipment must not be disposed of with the household waste at the end of its life. You will find collection points for free return of waste electrical and electronic equipment in your vicinity. The addresses can be obtained from your municipality or local administration. You can also find out about other return options that apply for many EU countries on the website <https://hub.trotec.com/?id=45090>. Otherwise, please contact an official recycling centre for electronic and electrical equipment authorised for your country.

The separate collection of waste electrical and electronic equipment aims to enable the re-use, recycling and other forms of recovery of waste equipment as well as to prevent negative effects for the environment and human health caused by the disposal of hazardous substances potentially contained in the equipment.



In the European Union, batteries and accumulators must not be treated as domestic waste, but must be disposed of professionally in accordance with Directive 2006/66/EC of the European Parliament and of the Council of 6 September 2006 on batteries and accumulators. Please dispose of batteries and accumulators according to the relevant legal requirements.

Trotec GmbH

Grebener Str. 7
D-52525 Heinsberg

☎ +49 2452 962-400

☎ +49 2452 962-200

✉ info@trotec.com

www.trotec.com